

# **AN EXOSKELETAL ROBOT MANIPULATOR FOR LOWER LIMBS REHABILITATION**

**Erhan AKDOĞAN<sup>1</sup> , M. Arif ADLI<sup>2</sup>**

<sup>1</sup>Marmara University, Vocational School of Technical Sciences, Goztepe, Istanbul  
e mail:[eakdogan@marmara.edu.tr](mailto:eakdogan@marmara.edu.tr)

<sup>2</sup>Marmara University, Department of Mechanical Engineering, Goztepe, Istanbul  
e mail:[adli@eng.marmara.edu.tr](mailto:adli@eng.marmara.edu.tr)

## **Abstract**

*There is an increasing trend in using robots for medical purposes. One specific area is the rehabilitation. There are some commercial exercise machines used for rehabilitation purposes. However, these machines have limited use because of their insufficient motion freedom. In addition, these types of machines are not actively controlled and therefore can not accomodate complicated exercises required during rehabilitation. In this study, three degree of freedom exoskeletal robot manipulator is proposed for lower limbs rehabilitation. The control of this robot manipulator is achieved by an intelligent controller. The robot operates in two stages; learning and therapy. It can make abduction-adduction and flexion-extension movements for hip, in addition to flexion-extension movement for knee.*

## **1 Introduction**

Complaints from legs and arms are the main source of human movement problems and are very common among people. Muscle weaknesses due to old ages, traffic and labour accidents or injuries during wars are the main reasons for human movement disabilities. To regain the ability of motion, one needs to strengthen the weak muscles. The process of strengthening muscles to their normal values is a costly labour which requires time and patience. In general a person with movement disabilities due to arm or leg problems needs to undergo periods of physiotherapy sessions (spread in a long time) which comprises a series of repeated and routine physical movements with the assistance (and under the observation) of a physiotherapist. Transporting the patient to the place of physiotherapy or calling a physiotherapist to the place of the patient are the factors that further increase the cost of this process. An intelligent instrument which replaces the duty of the physiotherapist and can accomplish such routine physical movements without the guidance and assistance of a physiotherapist will simplify the process and lower the costs drastically.

Devices called "Continuous Passive Motions (CPM)" shown in Figure 1, are widely used in many medical centers for therapy and rehabilitation purposes. The CPM concept was first introduced in the 1970' s (Salter & Simmonds 1980). However, these devices which are passively driven and have single degree of motion freedom in general are designed for performing exercises in the form of simple reciprocating motions only. Therapeutic devices should have multiple degrees of freedom. Because arm and leg

motions during physiotherapy may need sophisticated motions. For example, Krebs et al. have developed and have been clinically evaluating a robot-aided neurorehabilitation system called MIT-MANUS. This device provides multiple-degree of freedom (DOF) exercises of upper extremities for stroke patients (Krebs et. Al 1998). They are not actively controlled and do not incorporate any feedback from the patient during the motion. Also, the patient's reactions during the exercises need to be taken into consideration to change and control the exercises actively as a real physiotherapist will do. This can only be done with intelligent devices which can decide the type and pace of exercises based on the patient's complaints and reactions during the physiotherapy.

There is an increasing number of researches about the robot manipulators that will be used for physical therapy or rehabilitation purposes. Advances in intelligent control techniques have accelerated the research in this field. Most of the research is concentrated on devices which are used for rehabilitation of upper limb. Research projects run at University of California (Lum et. al 1993), MIT (Krebs et. al 1999), VA Palo Alto HCS (Lum et. al 1997), University of Delaware (Lum et. al 1999), Loughborough University (Taylor 1997), Harvard University and Boston Biomechanics Inc. (Matsuoka&Miller 1993) are examples to this. But for lower limb rehabilitation researchs haven't been as much as upper limb researchs. For lower limbs rehabilitation, a device named as TEM (Therapeutic Exercise Machine) has been proposed and developed by Sakaki et. al (1999). This machine is designed to carry out 3-DOF motion in the sagittal plane. Also, Homma et. al (2002), have proposed a multiple DOF rehabilitation system that employed a wire – driven mechanism.

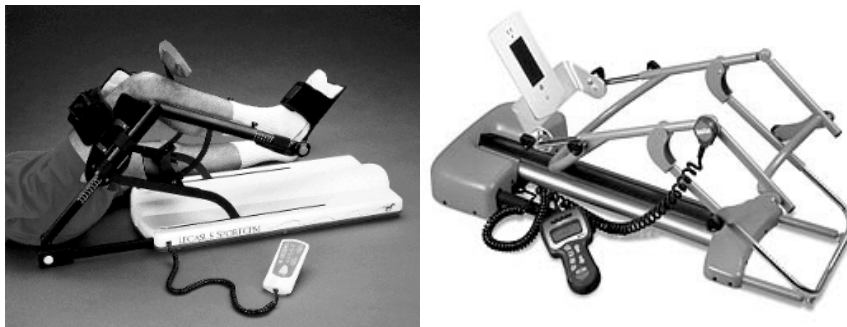

Figure 1. CPMs for Lower Limbs (Ref. 1&2)

With this study we proposed an exoskeletal robot manipulator which can accomplish the rehabilitation of lower limb based on the patient's complaints and the on line feedback during the rehabilitation process. The manipulator can provide three degrees of motion freedom which is enough to perform a wide range of exercises required in physical therapy and rehabilitation of the lower limb.

## **2 Types of Exercises (Kayhan 1995)**

There are four basic types of exercises used in rehabilitation processes. These exercises are shown in Figure 2, and explained in the following sections.

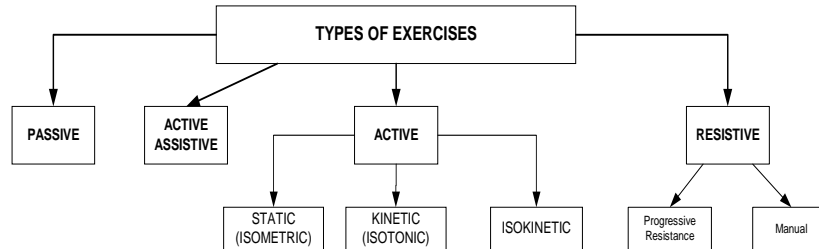

Figure 2. Types of Exercises

### 2.1 Passive Exercises

These exercises are performed for the patient by another person (nurse or therapist) or by an exercises device (robotic device or CPM). They are usually applied to patients who do not have muscle strength.

### 2.2 Active Assistive Exercises

As the patient develops the ability to produce some active movement, active exercises begin. Assistance can be provided manually by a therapist, by counterbalancing with weights or by gravity. These exercises are helpful in increasing the strength of the patient.

### 2.3 Active Exercises

These are the purposeful voluntary motion that are performed by the person himself, without resistance and with or without the aid of gravity. Active exercises may be static, kinetic or isokinetic.

**Static exercises** refer to contraction against a fixed resistance. No change in the joint angle occurs. **Kinetic exercises** refer to moving the resistance through a range of motion. **Isokinetic exercises**, refer to resistance exercise performed at a constant preset speed. The speed is kept constant by resisting accomodating to muscle effort (torque). Isokinetic exercise is applied by a machine.

### 2.4 Resistive Exercises

If exercise is desired to give some controlled resistance manually by therapist, it is called manual resistive exercise. In this method, multiple sets of an exercise are performed for 10 repetitions per set, with progressively increasing resistance up to the maximum of 10 repetition.

## 3 The Movements and Limits for Lower Limbs Rehabilitation

In hip and knee rehabilitation exercises, the process has two important movement. These are abduction-adduction and flexion – extension. Abduction is the act of drawing away the limb from the median plane of the body. Adduction is the act of drawing the limb

towards the median plane of the body. Flexion is the act of bending of the limb where as extension is the act of extending the limb.

For a human, adduction-abduction and flexion-extension movements and their limits for hip are shown in Figure 3 and 4.

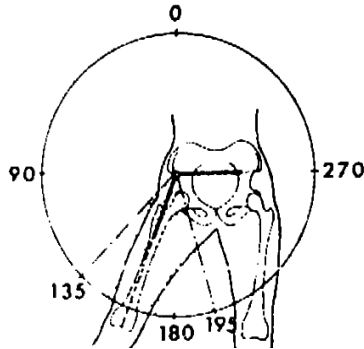

Figure 3. Abduction and adduction movements for hip

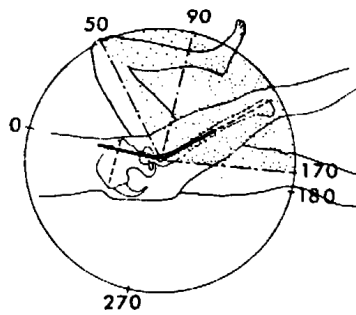

Figure 4. Flexion and Extension movements for hip

The flexion-extension movements and their limits for the knee are shown in Figure 5.



Figure 5. Extension and Flexion movements for knee

### 4 Proposed System Structure

The proposed system for lower limbs rehabilitation consists of four major elements; the therapist, the intelligent controller, the robot manipulator and the patient. Detailed block diagram of the proposed robot manipulator system is shown in Figure 6. The system can perform all types of exercises.

The system works in two stages, learning and therapy (application). While in learning mode, the system creates a database by using the data the therapist gave about the therapy and learns. The therapy information is comprised by the data of force, position applied by the therapist to the patient and the specialization of the therapist. Force and position data are provided by the force and position sensors. While in therapy mode, the system processes the information that was possessed in learning mode.

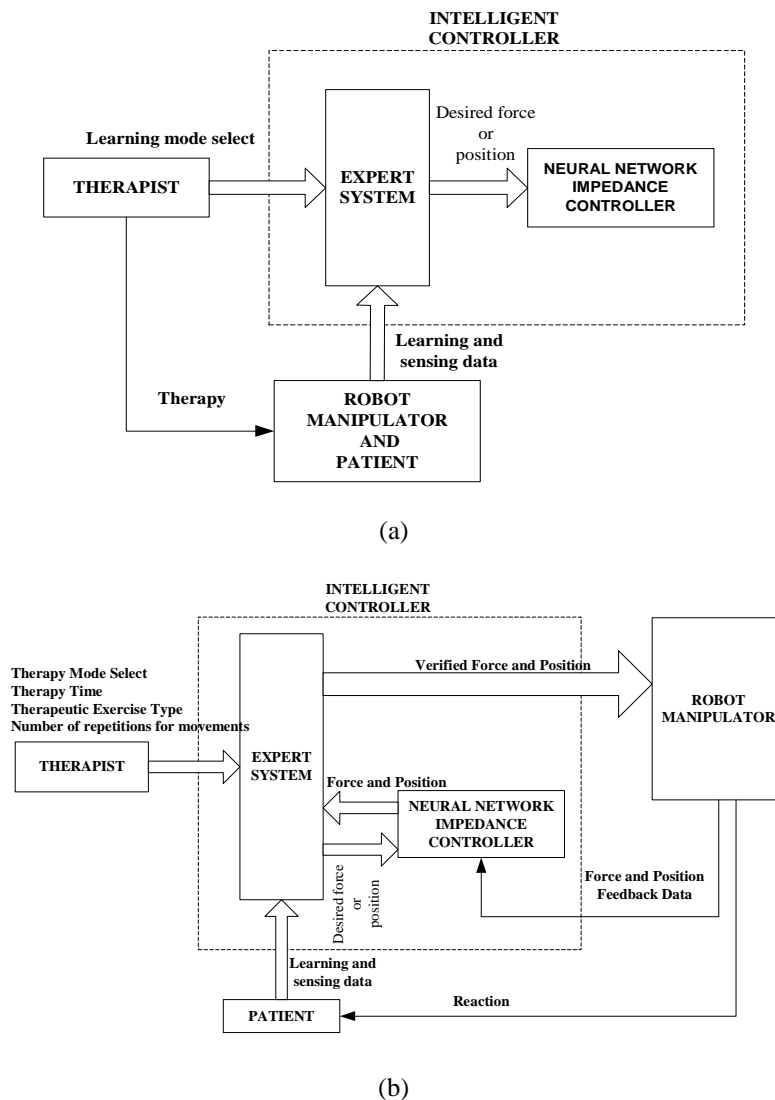

Figure 6. Detailed Block Diagram of Robot Manipulator System  
 a) Learning mode b) Therapy Mode

## **4.1 The Therapist**

The following applications are conveyed by the therapist via user interface.

- Mode selection (learning or therapy mode),
- Exercise type selection
- Exercise time
- Number of repetitions for movements (only for some exercise types)

## **4.2 Intelligent Controller**

The robot manipulator will be controlled by an intelligent controller which will incorporate the preloaded data about the patient and provide the interface for information flow between the manipulator and the patient. The function of intelligent controller is two fold. First, to form a database during the rehabilitation process done by a physiotherapist and learn the process based on the observation and database. Second, control the robot manipulator to perform the rehabilitation instead of physiotherapist or therapeutic exercises device.

Depending on the preloaded information, the controller will decide the forces and range of motion that will be applied to the limbs. Using force sensors, the reactions from the limbs will be feedback to the manipulator through the intelligent controller. The rehabilitation process and the forces applied to the limbs will be modified based on patient's reactions.

The intelligent controller has two major parts. These are an expert system and an impedance force controller. All input and output processes are controlled by the expert system, in the intelligent controller. Namely, the expert system is brain of intelligent controller.

In this study, impedance control technique is selected for the force control. With this aim, an impedance controller based on neural network is developed. The impedance control which was first proposed by Hogan (Hogan 1985) is the most appropriate control technique for the physiotherapy. The aim of impedance control is to specify the relationship between position and force. Desired force and position are connected through mass, spring and damping characteristics. Several prototype physiotherapy robots use this technique. Krebs et. al (1998), have implemented force based impedance control in the MIT – MANUS. Noritsigu and Yamanaka (1996) have used position based impedance control on a RAM (Rubber Artificial Muscle) for a prototype physiotherapy robot. This system incorporates additional pressure controllers to ensure. On the other hand, Richardson et. al (2000), proposed a simple pneumatic impedance control system for implementation on a physiotherapy robot.

## **4.3 Robot Manipulator and Control System Hardware**

The purpose of robot manipulator is also two fold. First, it will be used as an apparatus during the learning process when the physiotherapist perform the rehabilitation. During this process the lower limb will rest on the robot manipulator and using the force sensors and optical encoder (or resolver) on the manipulator the position and force data will be collected. Since the manipulator has three degrees of motion freedom, it can attain most of the possible motions of the lower limb required during the rehabilitation. The second use of robot manipulator which is indeed the main purpose is to function as a physiotherapist to rehabilitate the lower limbs after the learning process.

It is designed such that it can rehabilitate both left and right lower limbs. In addition, it can be adjusted for different limb dimensions. The manipulator is designed as a pantograph mechanism so that all actuator are located at the stationary ground.

The manipulator can perform the following motions for the rehabilitation of lower limbs.

- For hip; adduction - abduction, flexion – extension
- For Knee; flexion – extension

The architecture of the proposed rehabilitation manipulator is shown in Figure 7.

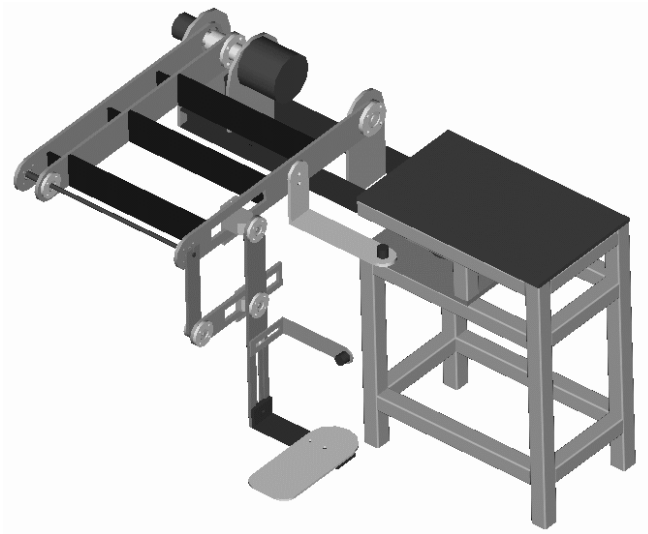

Figure 7. Architecture of Proposed Robot Manipulator

The system hardware for controlling the robot manipulator is shown in Figure 8.

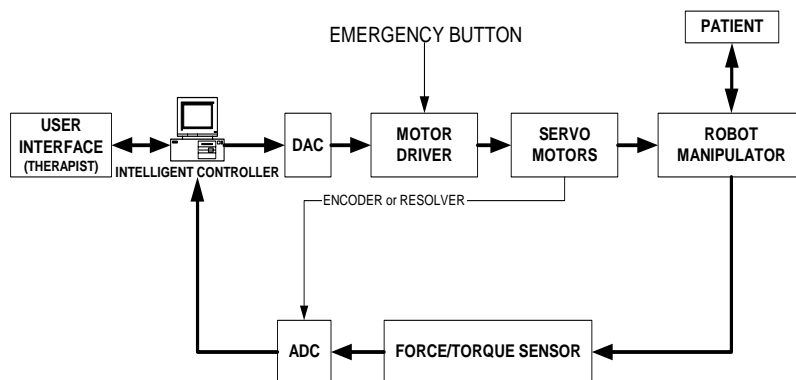

Figure 8. System Hardware

## 4 System Security

The security is very important in robots which are used in rehabilitation as it is in all kinds of medical instruments. For this purpose, the system security is controlled by both hardware and software. If the robot manipulator exceeds the acceptable force and position security limits, it will be automatically halted by the software. As an extra security, the outputs of NN impedance controller in intelligent controller are also controlled by an expert system. If the force data from the impedance controller is in the acceptable limits, the data is forwarded to the robot manipulator. Also a manual emergency button is available in the system.

## 5 Results And Discussion

An exoskeletal robot manipulator for rehabilitation of lower limbs is proposed. The manipulator is controlled by an intelligent controller. The function of intelligent controller is two fold. First, to form a database during the rehabilitation process done by a physiotherapist and learn the process based on the observation and database. Second, control the robot manipulator to perform the rehabilitation instead of physiotherapist or therapeutic exercises device. Intelligent controller is comprised of an expert system and impedance controller. The method of force control is impedance control, which is the most appropriate method for physiotherapy. For this purpose, an impedance controller based on Neural Network is developed.

Proposed robot manipulator mechanism has 3 degree of freedom. It can make abduction-adduction and flexion-extension movements for the hip, can make flexion-extension movement for the knee. The system security is an controlled by both hardware and software.

As a continuation of this research, besides force and position data with feedback data, bio-feedbacks such as EMG can be used. Also, the variations in joint muscles can be tracked by a graphical unit.

## 6 References

[www.arthroscopy.com/cpm.gif](http://www.arthroscopy.com/cpm.gif), reach time: 02.01.2004

<http://www.qhpinch2b.com/Therapy/CPM/knee.asp>, reach time:02.01.2004

Hogan N. (1985), Impedance Control: An approach to manipulation Part I, II, III, *Journal of Dynamic systems, Measurements and Control* **Vol.107/1**.

Homma K., Fukuda O., Nagata Y. (2002), Study of a Wire-Driven Leg Rehabilitation System, *Proceeding of Sixth Int. Conf. On Int. Robots and Systems*: 1451-1456.

Kayhan Ö. (1995), *Lectures and Seminars in Physical Medicine and Rehabilitation*, Marmara Universitesi Yayınları, İstanbul, Türkiye.

Krebs H.I., Hogan N., Aisen M.L., Volpe B.T. (1998), Robot Aided Neurorehabilitation, *IEEE Trans. On Rehabilitation Engineering* **Vol:6, No:1**, 75-87.

Krebs H.I., Hogan N., Hening W., Adamovich S., Poizner H. (1999), *Proc Int. Conf. On Rehabilitation Robotics*: 27-33

- Lum P.S., Reinkensmeyer D.J., Lehman S.L. (1993), *IEEE Trans. Rehab. Eng.* **1**: 185-191.
- Lum P.S., Burgar C.G., Van der Loos H.F.M. (1997), *Proc Int. Conf. On Rehabilitation Robotics*: 107-220
- Lum P.S., Burgar C.G., Van der Loos H.F.M. (1999), *Proc Int. Conf. On rehabilitation Robotics*: 235-239
- Matsuoka Y., Miller L.C. (1999), *Proc. Int. Conf on Rehabilitation Robotics*: 177-182
- Noritsigu T., Yamanaka T.(1996), Application of Rubber Artificial Muscle Manipulator as a Rehabilitation Robot, *Proc 5<sup>th</sup> IEEE Int Work shop Robot and Human Communucation*: 112-117.
- Rao R., Agrawal S.K., Scholz J.P. (1999), *Proc. Int. Conf on Rehabilitation Robotics*: 187-200
- Richardson R., Brown M., Plummer A.R. (2000), Pneumatic Impedance Control for Physiotherapy, *Proceedings of the EUREL Int. Conf. Robotics* **Vol. 2**.
- Sakaki T., Okada S., Okajima Y., Tanaka N., Kimura A., Uchida S., Taki M., Tomita Y., Horiuchi T. (1999), TEM:Therapeutic Exercise Machine for Hip and Knee Joints of Spastic Patients, *Proceeding of Sixth Int. Conf. On rehabilitation Robotics*: 183-186.
- Salter R., Simmonds B. W. (1980), The Biological Effect of Continuous Passive Motion on the Healing of Full Thickness Defects in Articular Cartilage: An Experimental Investigation in The Rabbit, *The Journal of Bone and Joint Surgery* **62-A**: 1232-1251.
- Taylor A.J. (1999), *Proc Int. Conf. On on Rehabilitation Robotics*: 39-42.